

TEAM 1 1265



TEAM 2 104



Planet Protector



Planet Protector



EASY CLEANING WITH ANTIBACTERIAL WIPES



This multiuser touchscreen game transforms a task that we're all too familiar with—tossing away rubbish—into a fun and meaningful sorting challenge.

As items float along the ocean current on the gameplay screens, players must determine which bin the rubbish belongs in before it floats away. Sorting categories include landfill, hazardous waste and recyclables. Points are gained for every item that is tossed into the correct bin and every item removed from the beach. Planet Protector is a timed challenge and players have 90 seconds to clean up the shore as quickly as possible, to earn the title “Planet Protector”.

AGES

- Children (5+) and Adults

LEARNING CONCEPTS

- Recycling and Waste Management
- Conservation & Sustainability
- Categorization



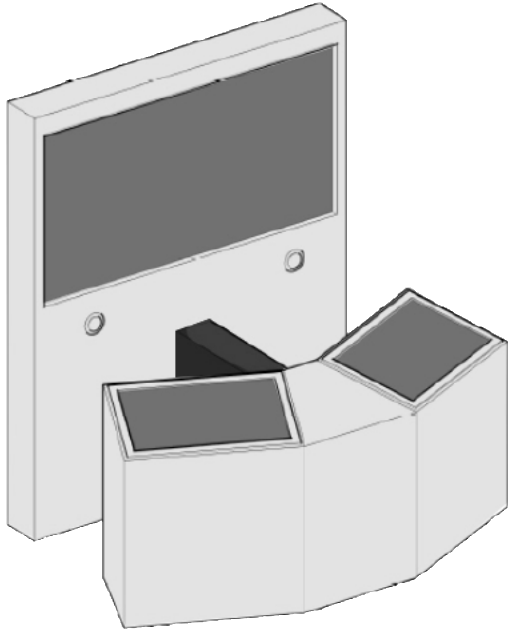

Standard Specifications

PHYSICAL UNIT	
 <p>Dimensions assembled: 63" (W) x 70.25" (H) x 44" (D)</p>	<p>Key Features:</p> <ul style="list-style-type: none"> • Single play • Playful learning with actionable lessons • Multi-touch, multi-player interactive game • Intuitive interface, easy to start, hard to master • Encourages friendly competition, interaction and replay • Back-end infrastructure provides gaming analytics for education team & stakeholders • Designed and built in the U.S.A.
	<p>Customization Options:</p> <ul style="list-style-type: none"> • Custom graphic and messaging for cabinet panels • Feature exhibit sponsor's logo • Items can be updated to match your locale requirements. • Language Localization
TECHNOLOGY	
<p>Components:</p>	<ul style="list-style-type: none"> (1) Industrial Display (55"); (2) Industrial Touch Displays (24"); (2) Speakers & amplifiers; (1) CPU & peripherals; (1) UPS backup; User Manuals
<p>Installation Requirements:</p>	<p>Plug and Play</p>

Company Profile

Beaudry Interactive is an award-winning experiential design and creative tech company based in Los Angeles. Our work spans museum exhibitions, themed entertainment, live shows, and branded experiences, all with a singular mission: provide an environment that actively engages, entertains and educates your guests.

We design and develop a wide range of interactive digital products that leverage our deep knowledge and expertise in designing innovative experiences for guests of all ages. Our success comes from utilizing our time-tested technologies, cross-discipline collaborations with our best-in-class partners in media, design and education, including subject matter experts in early learning and accessibility.



Capabilities



Interaction Design



Research & Development



Software & Hardware Development



Library of Interactive Products



Interactive Media



Playful Learning



Producing Capabilities



Space for Prototyping and Playtesting

Clients we've worked with



TEAM 1 1265

TEAM 2 104



Contact Us!

p +1.818.855.1206
www.binteractive.com
bi@binteractive.com