



Fish School

Fish School



EASY CLEANING WITH ANTIBACTERIAL WIPES



Turn any space into an interactive aquarium! Fish School is an interactive digital aquarium that teaches kids about fishes' unique adaptations to their aquatic habitats.

This large touchscreen tank is multi-user friendly, and invites guests to guide 3D fish between different aquatic zones, observing how the effects of new environmental conditions play out in real-time. Fish responds directly to guests' touch and actions.

This can be a standalone exhibit or part of a larger experience.

Developed in collaboration with



AGES

- Children (5+) and Adults

LEARNING CONCEPTS

- Early Biology: classification, aquatic habitats, adaptations
- Cause and Effect
- Cooperative Play



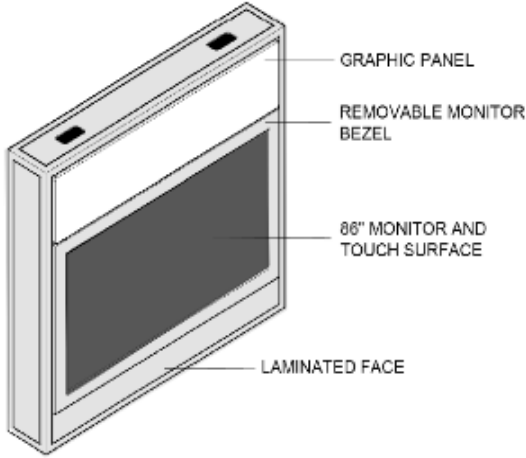
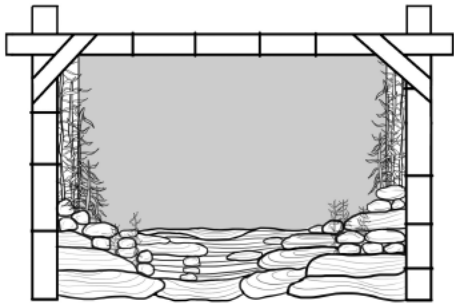
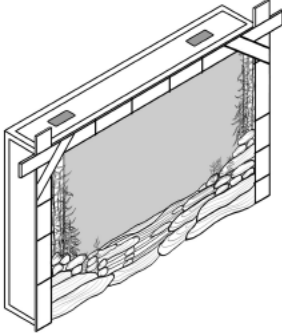

Standard Specifications

PHYSICAL UNIT	
 <p>7'4" (W) x 7' (H) x 1'2" (D)</p>	<p>Key Features:</p> <ul style="list-style-type: none"> • Multi-touch, multi-user educational exhibit • Reading not essential for play • Realistic 3D fish animations and aquatic environments • Duration: free play • Designed and built in the U.S.A.
	<p>Customization Options:</p> <ul style="list-style-type: none"> • Custom theme, graphics and educational messaging for cabinet panels • Feature exhibit sponsor's logo • Language Localization
TECHNOLOGY	
 <p>Aquarium Theme (front view)</p>	<p>Components:</p> <ul style="list-style-type: none"> (1) 86" Industrial Touch Display (2) Speakers (1) CPU & peripherals (1) UPS power backup; User manual
 <p>Aquarium Theme (isometric view)</p>	<p>Installation Requirements:</p> <p>Attach to the facility wall, then plug and play</p>

Company Profile

Beaudry Interactive is an award-winning experiential design and creative tech company based in Los Angeles. Our work spans museum exhibitions, themed entertainment, live shows, and branded experiences, all with a singular mission: provide an environment that actively engages, entertains and educates your guests.

We design and develop a wide range of interactive digital products that leverage our deep knowledge and expertise in designing innovative experiences for guests of all ages. Our success comes from utilizing our time-tested technologies, cross-discipline collaborations with our best-in-class partners in media, design and education, including subject matter experts in early learning and accessibility.



Capabilities



Interaction Design



Research & Development



Software & Hardware Development



Library of Interactive Products



Interactive Media



Playful Learning



Producing Capabilities



Space for Prototyping and Playtesting

Clients we've worked with





Contact Us!

p +1.818.855.1206
www.binteractive.com
bi@binteractive.com